

MediorNet MN-LNK8-CWDM / MN-LNK8-CWDM80

The MN-LNK8-CWDM(80) Link Card allows the interconnection to another MediorNet frame via one bi-directional duplex fiber connection with 8 different CWDM wavelengths.



- 4 internal SFP ports that support 4.25 Gigabit/s SFP modules
- 4 external fiber ports via LC connectors
- CWDM80 version is equipped with high power SFP for max. 80 km of fiber length
- Integrated CWDM multiplexing / de-multiplexing
- Multiplexing on one single-mode duplex fiber, accessible via LC connector
- Support of single-mode SFP transceivers only
- Different wavelengths are used in the various MediorNet cards.
The 'MN-LNK8-CWDM(80) MUX' port must only be connected to a 'MN-LNK8-CWDM(80) MUX' or 'MN-LNK18-CWDM ADD' port.
- The external wavelengths are multiplexed passively to the MUX port of the card.
The frame with the MN-LNK8-CWDM(80) Card is not able to access the external signals.
- A removable 3dB attenuation is placed by default at the MUX output port (not in CWDM80 version).
- The MN-LNK8-CWDM(80) Link Card must be fitted into a 4x High-Speed slot and it occupies one slot, so it can be placed in the slots 7 and 10 of the Modular mainframe.

Block Diagram

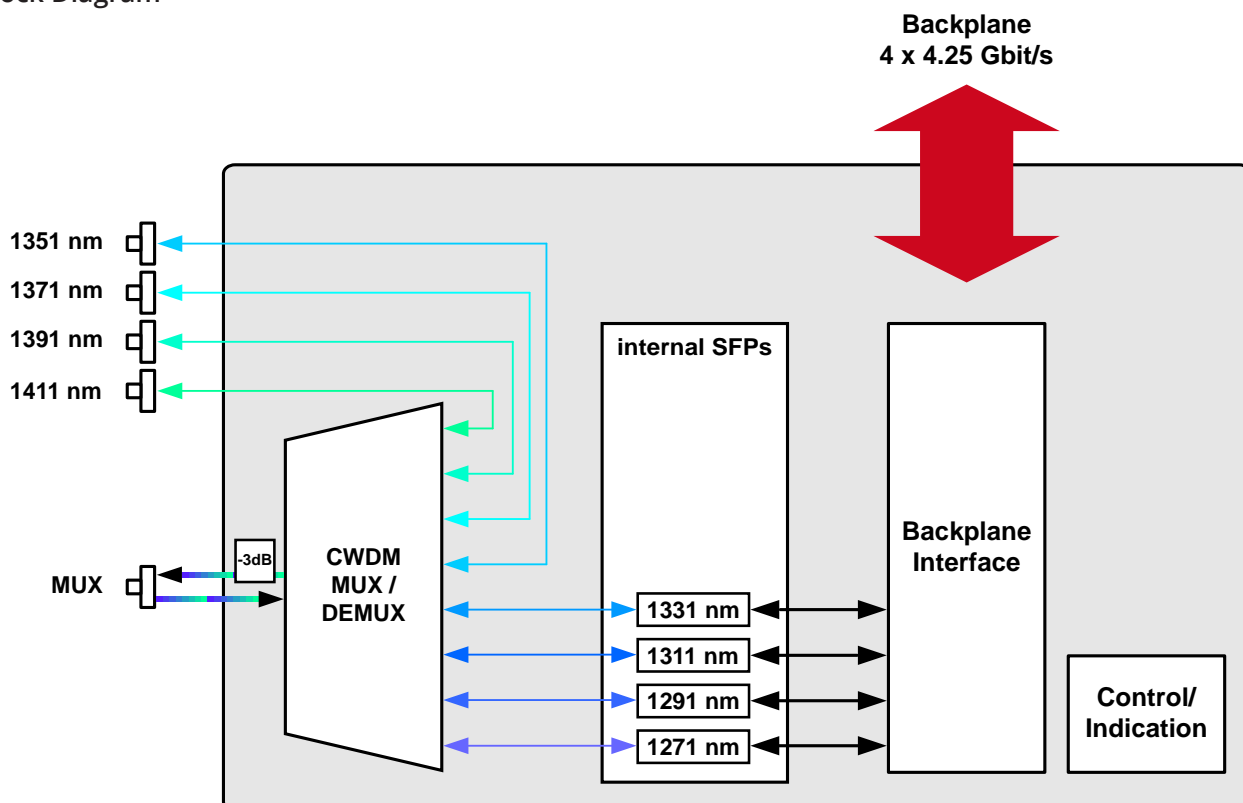

MediorNet MN-LNK8-CWDM / MN-LNK8-CWDM80

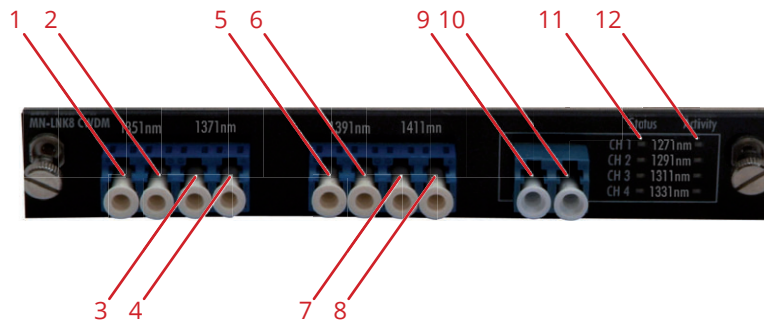

Legend

- 1) ADD Port 1351 nm TX
- 2) ADD Port 1351 nm RX
- 3) ADD Port 1371 nm TX
- 4) ADD Port 1371 nm RX
- 5) ADD Port 1391 nm TX
- 6) ADD Port 1391 nm RX
- 7) ADD Port 1411 nm TX
- 8) ADD Port 1411 nm RX
- 9) MUX 1271 - 1411 nm TX Port
- 10) MUX 1271 - 1411 nm RX Port
- 11) Status LEDs internal channels 1 - 4
- 12) Activity LEDs internal channels 1 - 4

Status LEDs

	off	green	orange	red
Link Status	No SFP present	SFP present, link up	SFP present, link down	Link active, SFP RX power error
Link Activity	No connection	Connections present and OK	--	Connections present and damaged

Bi-Directional Ports

Mux/Demux Specifications	
Channel Number	8
Central Wavelength	1271, 1291, 1311, 1331, 1351, 1371, 1391, 1411 nm
Passband	min. $\lambda_c \pm 6.5$ nm
Mux Isolation	min. 15 dB Adjacent Ch. min. 15 dB Non-adjacent Ch.
Demux Isolation	min. 30 dB Adjacent Ch. min. 40 dB Non-adjacent Ch.
Ripple in Passband	max. 0.3 dB
Directivity	min. 50 dB
Polarization Dependent Loss	max. 0.15 dB
Polarization Mode Dispersion	max. 0.10 ps
Return Loss	min. 45 dB
Insertion Loss	max. 1.5 dB
MUX Port total Input Power*	min/max: -7.5/+7.5 dBm MN-LNK8-CWDM80: -13.5/+4.5 dBm
MUX Port total Output Power*	min/typ/max: +4.5/+7/+9.5 dBm (including the 3dB opt. attenuation at the MUX output connector) MN-LNK8-CWDM80: +7.5/+10/+12.5 dBm
ADD Port total Input Power	min/max: 0/+5 dBm MN-LNK8-CWDM80-H: 0/+5 dBm
ADD Port total Output Power	min/max: -18/-3 dBm MN-LNK8-CWDM80-H: -24/-6 dBm

* all channels in use

SFP Specifications	
The specifications of all Riedel recommended SFP modules are listed in the MN-SFP Datasheet	
Single SFP Input Power	min/max: -18/-3 dBm
Single SFP Output Power	min/typ/max: 0/+2.5/+5 dBm

Possible Link Combination	min. opt. Budget with/without opt. attenuation at the LNK8 MUX output connector	min. - max. Fiber length with/without opt. attenuation at the LNK8 MUX output connector
LNK8 to LNK8	12 / 15 dB	0 - 48 / 12 - 60 km (with opt. attenuation of 0.25 dB/km) 0 - 34 / 9 - 43 km (with opt. attenuation of 0.35 dB/km)
LNK8-80 to LNK8-80	21 dB	0 - 84 km (with opt. attenuation of 0.25 dB/km) 0 - 60 km (with opt. attenuation of 0.35 dB/km)

Overall

Environmental Temperature	-5 °C to +40 °C (Non-condensing)
Supply Voltage	12 VDC
Power Consumption	5 W
Dimensions (w×h×d)	132 mm × 20 mm × 307 mm
Weight	440 g